

MOTOR TESTING AND DIAGNOSTICS



INTRODUCTION

Induction motors drive the majority of rotating equipment used in industry, including pumps, fans, and compressors.

Motors require periodic testing and analysis to:

- **Avoid unexpected failures / system downtime**
- **Trend performance and plan maintenance**
- **Maximize efficiency**

Recent improvements in motor test equipment and analytical software have enhanced the ability to quickly analyze and find solutions to motor problems.

Testing can usually be performed with the equipment operating.

ProPump Services has experienced engineers with specialized test equipment to provide a condition assessment of your motor, diagnose problems, and make recommendations for corrective action.

TYPICAL SCOPE OF WORK

A Diagnostic Specialist will visit your site, review the motor operating and maintenance history, and perform specialized testing such as:

Rotor Condition Assessment

- Frequency analysis of motor current
- Detection of broken rotor bars
- Shorted or open rotor laminations
- Condition of end-rings
- Porosity in aluminum cast rotors

Stator Condition Assessment

- Air gap symmetry
- Voltage phase balance
- Magnetic flux symmetry
- Electrical connections

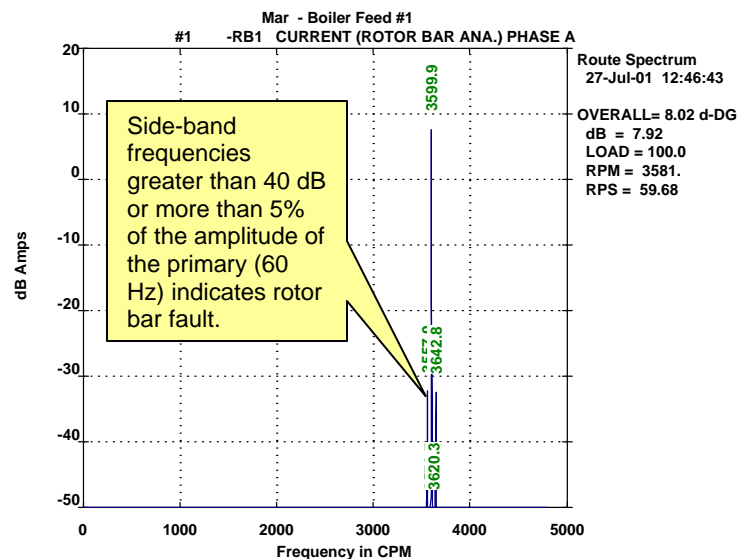

Current Spectrum Broken Rotor Bar

MOTOR TESTING AND DIAGNOSTICS



Vibration Spectrum Analysis

- Root cause analysis by frequency content
- Assessment of overall and peak values
- Analysis of vibration signatures
- Condition of bearings
- Evaluation of mounting foundation

TYPICAL INSTRUMENTATION

- Current waveform analyzer
- Magnetic flux sensor
- Multi-channel vibration analyzer
- Post processing software

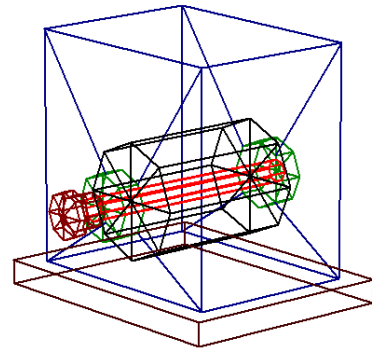

DELIVERABLES

- Summary report including historical background, testing methods, data collected, conclusions, and recommendations

